

High Order Harmonics Elimination in Modified Single Phase 5-level Cascaded H-bridge Inverter Using HGA

Fayçal CHABNI, Rachid TALEB, M'hamed HELAIMI

Electrical Engineering Department, Hassiba Benbouali University
Laboratoire Génie Electrique et Energies Renouvelables (LGEER), Chlef, Algeria
chabni.fay@gmail.com

Abstract: *The main objective of this work is to improve the quality of voltage waveform generated by a modified multilevel inverter cascade topology using Selective Harmonic Elimination (SHEPWM) control strategy and also using LC filters. The SHEPWM method is used to eliminate harmonics of chosen lower-order while controlling the amplitude of fundamental harmonic in CHB multilevel inverter. LC filter is added to the inverter in order to eliminate the high-order harmonics. Optimal switching angles are obtained by solving a non-linear equations system using Hybrid Genetic Algorithm (HGA). 5 level configuration for the new topology is presented in this work. The obtained simulation results are validated through experimental tests.*

Key words: *DC-AC power converters, Hybrid genetic algorithms, Optimization, Power harmonic filters, Power quality.*

1. Introduction

Multilevel DC to AC power converter configuration can be achieved by connecting several individual converters in series. By increasing the number of converters and DC sources, the AC output voltage become more similar to a sinusoidal waveform.

There are three main categories of multilevel inverters, Diode-clamped, flying capacitor and cascade H-bridge inverters [1]. The cascade DC to AC converters are easy to control, and they have a simple modular structure, the number of voltage levels could be increased by connecting additional H-bridge modules in series without changing the inverter's structure.

The cascade multilevel inverters provide a lot of advantages such as low Harmonic Distortion (THD), low electromagnetic interference [2], low voltage stress on semiconductor switches and an output voltage similar to a sinusoidal waveform which make them widely used in high and medium power applications electrical transmission systems.

Several modulation methods were used to control multilevel inverters such as space vector and sinusoidal PWM [3-5], a more effective modulation strategy called Selective Harmonic Elimination PWM (SHEPWM) is also used in the control of multilevel

inverters, the method provides numerous advantages such as reducing low order harmonics and the possibility of driving the semiconductor switches at low frequencies [6, 7]. In This work, a passive LC filter is added to the CHB multilevel inverter in order to eliminate high-order harmonics.

Genetic Algorithm (GA) is a very powerful algorithm that can solve almost all optimization problems, it mimics the process of natural evolution, and it is frequently used to obtain optimal solutions [8-10]. The hybrid genetic optimization algorithm has been developed to solve the fine-tuning problem of a local search in GA. It is a combination of Local Search [11-13] and GA.

In this work, a HGA with local search method has been applied to determine the optimal switching angles for the proposed CHB multilevel inverter. Computer simulations using MATLAB software and experiments using a small scale laboratory were carried out to evaluate the results obtained by the proposed converter for a five level configuration.

The structure of the proposed CHB multilevel inverter is presented in Section 2. In Section 3, a HGA based SHE modulation strategy is explained, the section also presents a general formulation of the SHE problem for the proposed converter. The results obtained from simulations and experiments of the control strategy are presented in Section 4. The conclusion is presented in section 5.

2. Proposed 5-Level CHB Inverter

Cascade H-bridge multilevel inverter topology requires least number of semiconductor switches, gate-drives and protection circuits comparing to other types and configurations of multilevel DC to AC converters. The asymmetrical configuration for multilevel inverters provides more voltage output levels for the same number of semiconductor switches than the symmetrical configuration, therefore improving the voltage waveform quality.

Fig. 1 illustrates the structure of the proposed single-phase 5-level CHB inverter, it consists of two H-bridge modules connected in series, V_{dc} is the isolated DC voltage source for the H-bridge module, $V_{AC} = V_{LC1} - V_{LC2}$ is the AC output voltage obtained via a two LC filter. Table 1 present the output voltage values of different switching states for 5-level inverter.

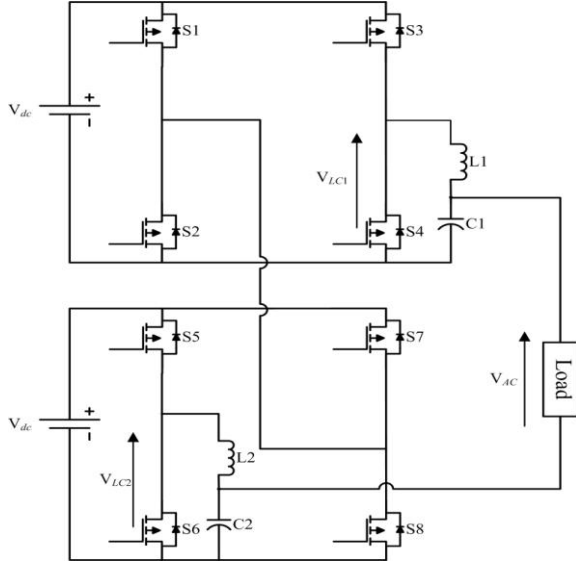

Fig. 1. Proposed single-phase 5-level CHB inverter

Table 1. Output voltage level with corresponding conducting switches of 5-level inverter

Output voltage level (<i>p.u.</i>)	switches in ON state
2	S2,S3,S6,S7
1	S2,S3,S6,S8
0	S2,S4,S6,S8
-1	S1,S4,S6,S8
-2	S1,S4,S5,S8

Considering the inverter direct output fundamental, the LC filter transfer function is given by:

$$T = \frac{V_{C1}}{V_{LC1}} = \frac{1}{1 - x^2 + jxy} \quad (1)$$

where $x = \omega\sqrt{LC}$, $y = R\sqrt{C/L}$, ω is the fundamental angular frequency and R represents the internal inductors resistance.

The transfer function magnitude of the filter is expressed by:

$$|T| = \frac{1}{\sqrt{(1-x^2)^2 + x^2y^2}} \quad (2)$$

The maximum value T_{max} of T , can be expressed by:

$$\begin{cases} T_{max} = T_{\omega_{max}} = \frac{1/y^2}{\sqrt{1/y^2 - 0.25}} \\ \omega_{max} = \frac{\sqrt{2}}{RC} \sqrt{1 - 0.5y^2} \end{cases} \quad (3)$$

The maximum angular frequency ω_{max} exists if $y < 1.4142$. The filter transfer function will present a peak value and then decreases to zero. Consequently, the fundamental and harmonic components are amplified, which leads to the undesirable effects, as it is shown in Fig. 2.

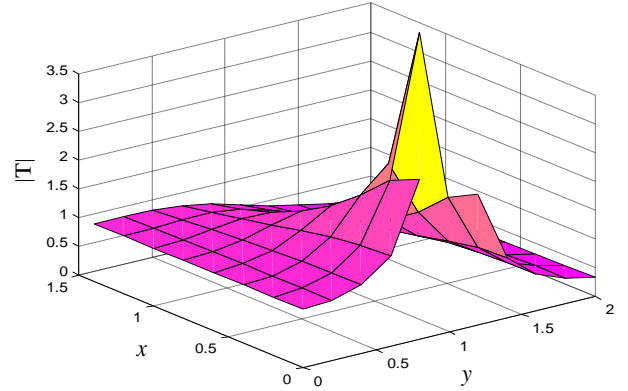

Fig. 2. Transfer function of the LC filter for the fundamental

3. Selective Harmonic Elimination with HGA

3.1. General formulation of SHE in proposed inverter

The SHEPWM is based on the Fourier analysis of the voltage waveform presented in (Fig. 3). Since the voltage waveform generated by the power converter is symmetric in a half and a quarter of a period, the even harmonics are equal to zero. The Fourier expansion for the V_{AC} voltage is thus:

$$V_{AC} = \sum_{n=1,3,5,\dots}^{\infty} V_n \sin(n\omega t), \text{ with } V_n = \frac{4V_{dc}}{n\pi} \sum_{i=1}^p \cos(n\theta_i) \quad (4)$$

where V_n is the amplitude of the harmonic term of rank n , $p = (N - 1)/2$ is the number of firing angles per quarter waveform, N is the number of generated voltage levels and θ_i is the switching angle of rank i .

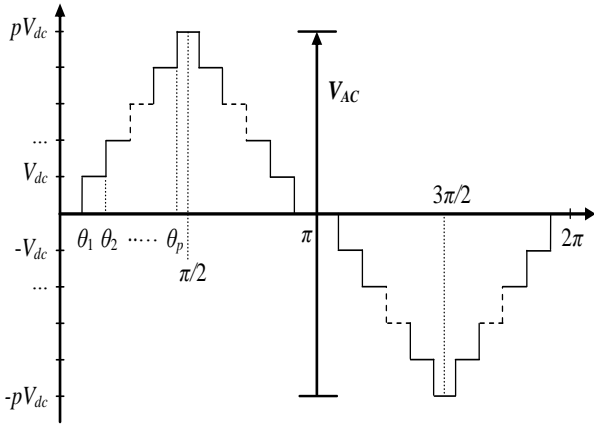

Fig. 3. Generalized output voltage waveform of a CHB multilevel inverter

The p switching angles in (4) are computed by fixing the value of the fundamental component term and setting the $p - 1$ other harmonic terms to zero. The value of these angles can be determined by solving the following system:

$$\begin{cases} \sum_{i=1}^2 \cos(\theta_i) = \frac{\pi}{2} r \\ \sum_{i=1}^2 \cos(3\theta_i) = 0 \end{cases} \quad (5)$$

where $r = V_1/pV_{dc}$ is the modulation index. The solution of (5) must also satisfy the following constraint:

$$0 < \theta_1 < \theta_2 < \dots < \theta_p < \pi/2 \quad (6)$$

An objective function is then needed for the optimization procedure; the function must be formulated in such way that allows the elimination of targeted harmonics, therefore objective function was chosen to be as follows:

$$F(\theta) = F(\theta_1 \dots \theta_p) = \left(\sum_{i=1}^p \cos(\theta_i) - \frac{p\pi}{4} r \right)^2 + \sum_{n=3,5,\dots}^{2p-1} \sum_{i=1}^p \cos(n\theta_i) \quad (7)$$

The optimal switching angles are obtained by minimizing the objective function presented in (7) while respecting the constraint presented in (6). The biggest problem is the non-linearity of the equations presented in (5); multiple computational techniques were used to solve SHE problems such as Newton-Raphson method [14, 15], resultant theory [16-18] and

Walsh function [19, 20], these methods are either complicated or require an initial guess of the optimal solutions, which can be extremely difficult especially for a large number of switching angles. It is, therefore, worth considering more techniques and simple techniques such as Hybrid Genetic Algorithms (HGA).

3.2 Solution using HGA

The hybrid genetic optimization algorithm has been developed to solve the fine-tuning problem of a local search in GA. The HGA is mixture of genetic optimization algorithm and a Local Search (LS) method [11-13]. In this work, a Hybrid Genetic Algorithms with local search method has been applied to determine the optimal switching angles by using the MATLAB optimization toolbox. A flowchart of the HGA algorithm for SHE is shown in Fig. 4.

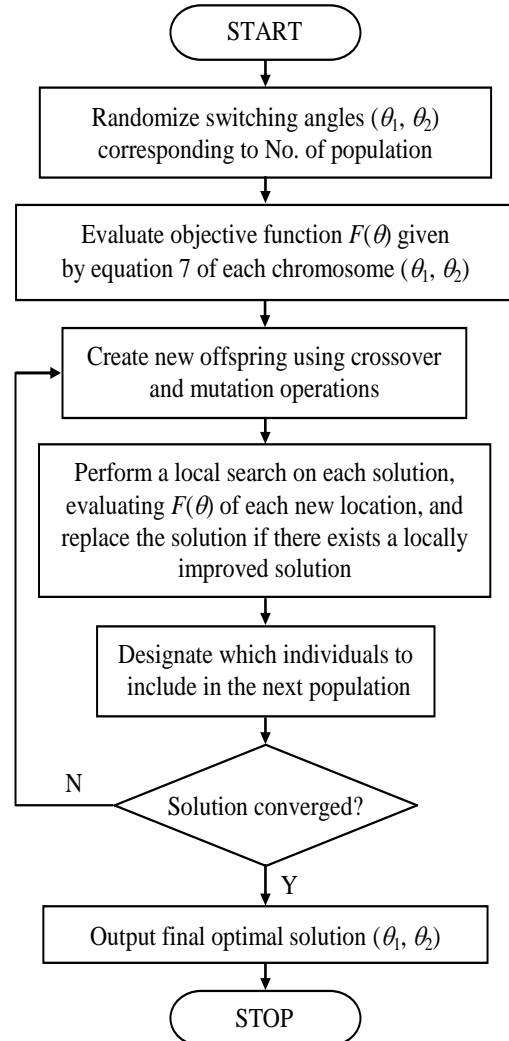

Fig. 4. Flowchart of HGA for the proposed inverter

The value of the presented objective function is minimized by using Hybrid Function which operates after the terminating of the GA. The determined final point from GA is used for Hybrid Function as an initial point. In this study, *fmincon* which is a Local Search method is preferred as hybrid function, *fmincon* is used to find a minimum value of the proposed cost function.

This algorithm was used to find the switching angles (θ_1, θ_2) to eliminate the 3rd harmonic of 5-level inverter. The results are plotted in Fig. 5 versus r , where $0.4 \leq r \leq 0.95$ with a step of 0.01. The THD corresponding to the solutions given in Fig. 5 is represented by Fig. 6.

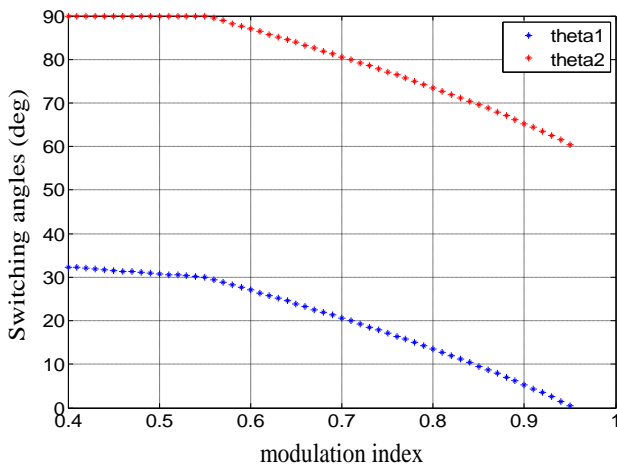

Fig. 5. Optimal switching angles versus r for single phase 5-level CHB inverter

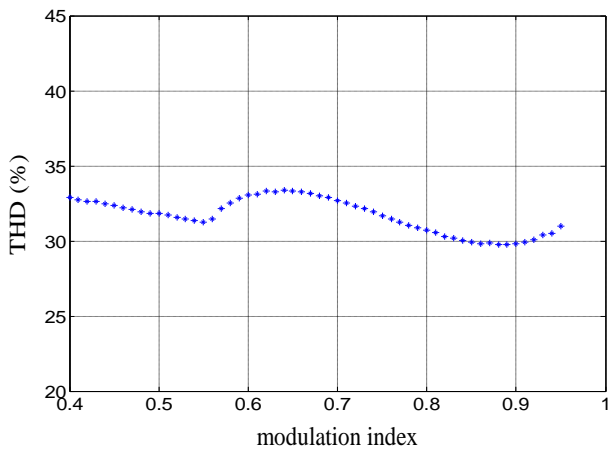

Fig. 6. THD versus r for optimal switching angles

4. Simulation and experimental results

A laboratory prototype of a proposed single-phase 5-level CHB inverter was built using IRF840 (500V, 8A) MOSFETs as the switching devices, and IR2112 as MOSFET gate drivers, 4N25 optoisolators for

protection, and two laboratory variable power supplies. Atmel SAM3X8E microcontroller was used to generate control signals. SDS1000 siglent digital storage oscilloscope was used to capture voltage signals. Fast Fourier Transform (FFT) and THD calculations were performed by computer linked to the SDS1000 digital oscilloscope via USB connection. Fig. 7 shows the experimental setup used in this study.

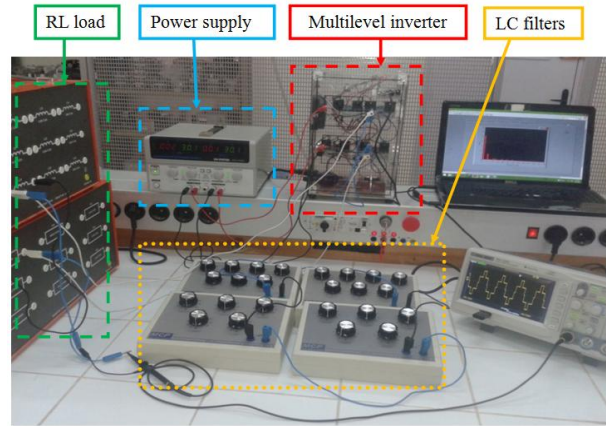

Fig. 7. Experimental setup

Figs. 8 and 9 show respectively simulated and experimental output voltages inverter and the corresponding FFT without LC filter (unfiltered output voltage) and with LC filter (filtered output voltage) of 5-level inverter for $r = 0.86$ (i.e. $\theta_1 = 7.054^\circ$, $\theta_2 = 67.05^\circ$) with $V_{dc} = 15V$ and the filter parameters $y = 0.2$.

The waveform representing the experimental results in Fig. 9 is practically identical to the one obtained by simulation in Fig. 8. The filtered inverter output voltage is perfectly sinusoidal. From the experimental results of unfiltered FFT output voltage, it is seen that the 3rd harmonic is efficiently eliminated as obtained in the simulation. All high frequency harmonics of filtered FFT output voltage are cancelled which proves the efficiency of the proposed inverter.

Table 2 presents the THD during experimental testing, and it is found that there is a significant improvement of the THD using the passive filter.

Table 2. Experimental measurement of THD

Unfiltered output voltage	Filtered output voltage
27.42%	2.9%

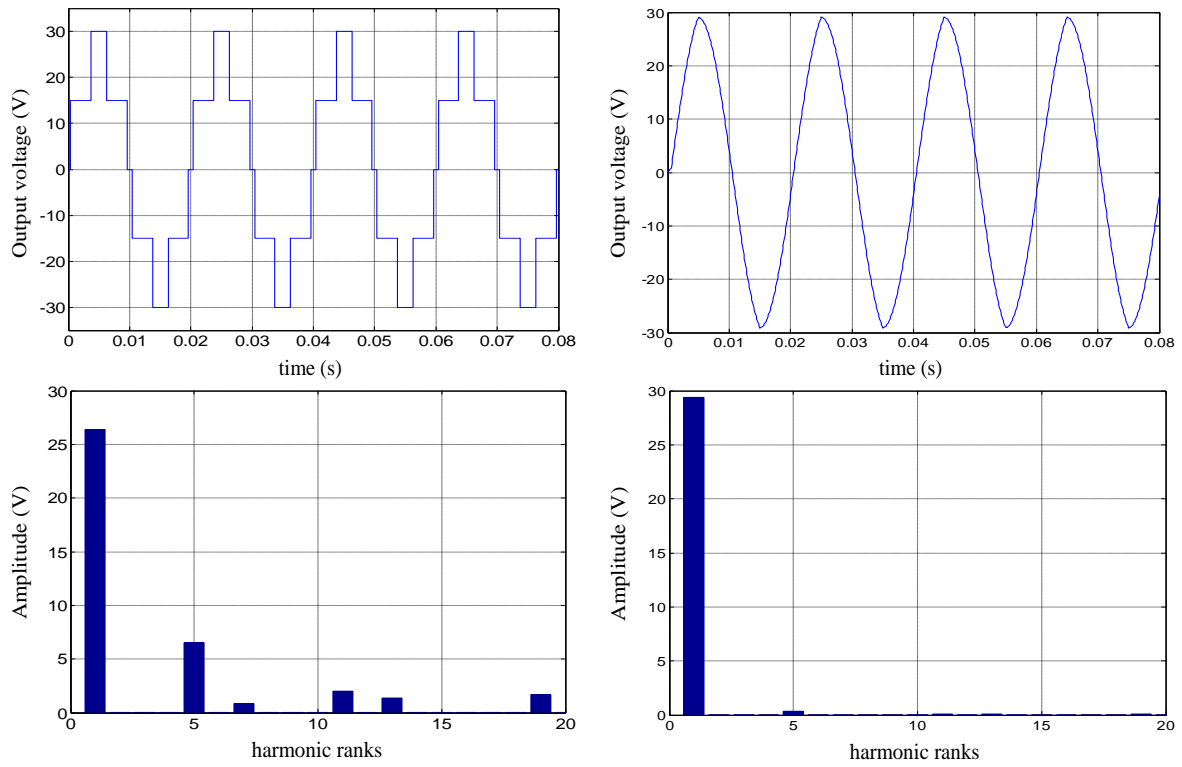

Fig. 8. Simulated output voltages and the corresponding FFT of 5-level inverter without LC filter (left) and with LC filter (right) for $r = 0.86$, $V_{dc} = 15V$ and $y = 0.2$

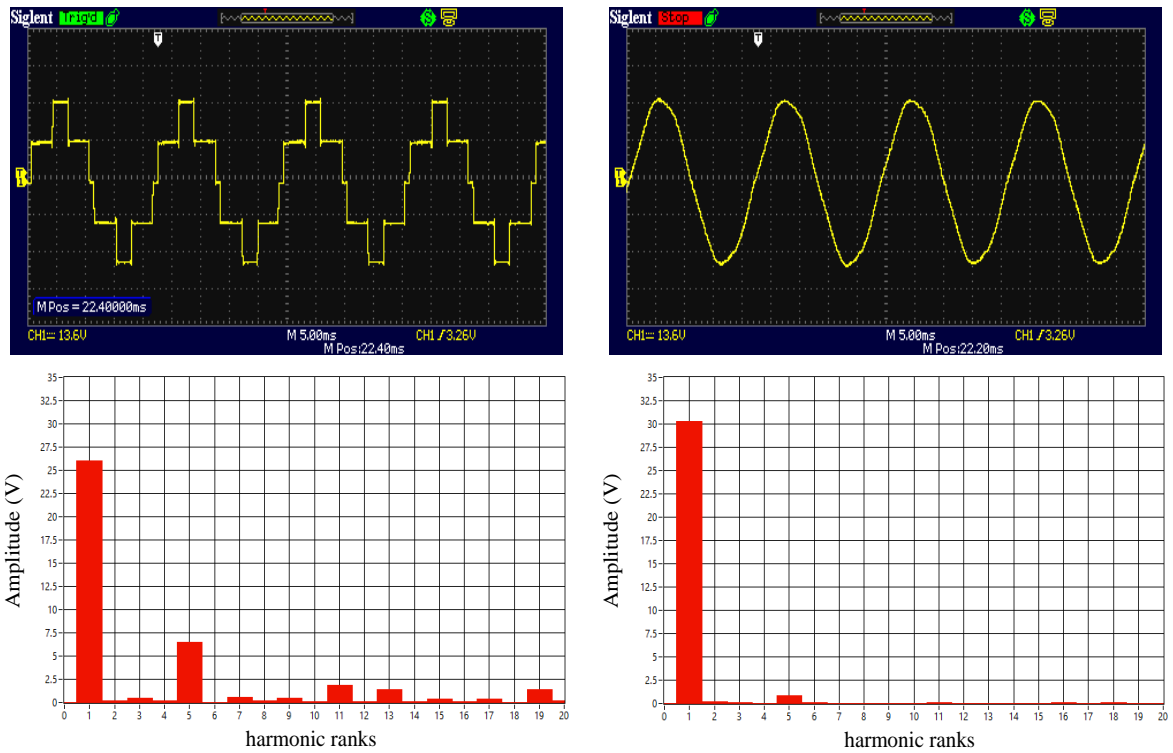

Fig. 9. Experimental output voltages and the corresponding FFT of 5-level inverter without LC filter (left) and with LC filter (right) for $r = 0.86$, $V_{dc} = 15V$ and $y = 0.2$

5. Conclusions

In this paper, a single-phase 5-level CHB inverter is developed by combining selective harmonic elimination and a passive LC filter to eliminate the output voltage harmonics. The overall system model requires solving a set of nonlinear transcendental equations for the optimal switching angles calculation. The proposed CHB multilevel inverter architecture and the harmonic elimination control strategy based on hybrid genetic algorithms make the system very efficient. The reduced switching frequency of the semiconductor switches provides more reliability and increases system components life time. The use of the LC passive filler canceled significantly the higher order harmonics in the output voltage waveform. The obtained results from experimental tests show a good agreement with the results obtained in simulation.

References

1. R.S. Alishah, D. Nazarpour, S.H. Hosseini, M. Sabahi, *Novel Topologies for Symmetric, Asymmetric, and Cascade Switched-Diode Multilevel Converter With Minimum Number of Power Electronic Components*, IEEE Transactions on Industrial Electronics, vol. 61, no.10, pp. 5300-5310, October 2014.
2. M.G. Sundari, M. Rajaram, S. Balaraman, *Application of improved firefly algorithm for programmed PWM in multilevel inverter with adjustable DC sources*, Applied Soft Computing, vol. 41, pp. 169-179, April 2016.
3. S.E. Rezgui, H. Benalla, *New Robust and Mechanical Sensorless Scheme for SVM Inverter Fed Induction Motor Drive Using Variable Structure Controllers and MRAS*, Arabian Journal for Science and Engineering, vol. 38, no. 6, pp. 1449-1458, June 2013.
4. M. Trabelsi, L. Ben-Brahim, T. Yokoyama, A. Kawamura, R. Kurosawa, T. Yoshino, *An improved SVPWM method for multilevel inverters*, 15th International Power Electronics and Motion Control Conference (EPE/PEMC), Novi Sad, pp. LS5c.1-1-LS5c.1-7, 4-6 September 2012.
5. M. Haris, M.K. Pathak, P. Agarwal, *Comparison of SPWM multilevel inverter fed PMSM drive with two level inverter fed drive*, IEEE International Conference on Recent Advances and Innovations in Engineering (ICRAIE), pp. 1-5, Jaipur, India, 9-11 May 2014.
6. C. Buccella, M.G. Cimatorni, H. Latafat, G. Graditi, R. Yang, *Selective harmonic elimination in a seven level cascaded multilevel inverter based on graphical analysis*, 42nd Annual Conference of the IEEE Industrial Electronics Society, IECON'16, pp. 2563-2568, Florence, Italy, 2016.
7. K. Ganesan, K. Barathi, P. Chandrasekar, D. Balaji, *Selective Harmonic Elimination of Cascaded Multilevel Inverter Using BAT Algorithm*, Procedia Technology, vol. 21, pp. 651-657, 2015.
8. M. A. Lasheen, F.M. Bendary, S.M. Sharaf, H.M. El-Zoghby, *Maximum Power Point Tracking of a Wind Turbine Driven by Synchronous Generator Connected to an Isolated Load Using Genetic Algorithm*, Journal of Electrical Engineering, vol. 15, no. 2, pp. 163-171, 2015.
9. D.E. Ghouraf, A. Naceri, W. Kabi, *The power system stabilizers synthesis by the genetic algorithms*, Journal of Electrical Engineering, vol. 14, no. 2, pp. 304-309, 2014.
10. A. Khattara, M. Becherif, M. Bahri, A. Aboubo, *Choice of Wind Turbine Location According to its Influence on the Optimization of the Economic Dispatch Problem Using Genetic Algorithm Method*, Journal of Electrical Engineering, vol. 14, no. 3, pp. 302-308, 2014.
11. I. Maatouk, N. Chebbo, I. Jarkass, E. Chatelet, *Maintenance Optimization using Combined Fuzzy Genetic Algorithm and Local Search*, IFAC-PapersOnLine, vol. 49, no.12, pp. 757-762, 2016.
12. S.M. Farhad, Muhammad Ali Nayeem, Md. Khaledur Rahman, M. Sohel Rahman, *Mapping stream programs onto multicore platforms by local search and genetic algorithm*, Computer Languages, Systems & Structures, vol. 46, pp. 182-205, November 2016.
13. V. Soam, L. Palafox, H. Iba, *Multi-objective portfolio optimization and rebalancing using genetic algorithms with local search*, IEEE Congress on Evolutionary Computation (CEC), pp. 1-7, Brisbane, 10-15 June 2012.
14. Krismadinata, N.A. Rahim, H.W. Ping, J. Selvaraj, *Elimination of Harmonics in Photovoltaic Seven-level Inverter with Newton-raphson Optimization*, Procedia Environmental Sciences, vol. 17, pp. 519-528, 2013.
15. T. Mistry, S.K. Bhatta, A.K. Senapati, A. Agarwal, *Performance improvement of induction motor by Selective Harmonic Elimination (SHE) using Newton Raphson (N-R) method*, International Conference on Energy Systems and Applications, Pune, pp. 364-369, 30 October - 01 November, 2015..
16. S. Sangeetha, S. Jeevananthan, *A software tool for selective harmonic elimination in multilevel inverters using Mathematica and Visual C++*, Nirma University International Conference on Engineering, pp. 1-6, Ahmedabad, Gujarat, 8-10 December 2011.
17. L. QingFeng, W. HuaMin, L. ZhaoXia, *A Novel Harmonics Elimination Method of Cascaded Multilevel Inverter*, TENCON'06, IEEE Region 10 Conference, pp. 1-4, Hong Kong, 14-17 November 2006.
18. R. Taleb, A. Derrouazin, *USAMI Control with a Higher Order Harmonics Elimination Strategy based on the Resultant Theory*, Energy Procedia, vol. 50, pp. 1045-1055, 2014.
19. S.G. Rosu, C. Radoi, A. Florescu, O. Stocklosa, *Microcontroller-based Walsh function PWM modulation with harmonic injection technique*, IEEE International Conference on Automation Quality and Testing Robotics (AQTR), pp. 1-6, Cluj-Napoca, 28-30 May 2010.
20. C. Zheng, B. Zhang, D. Qiu, *Solving switching angles for the inverter's selected harmonic elimination technique with Walsh function*, International Conference on Electrical Machines and Systems, vol. 2, pp. 1366-1370, Nanjing, September 2005.