

HIGH VOLTAGE SUBSTATION POLLUTION MAINTENANCE: THE USE OF RTV SILICONE RUBBER COATINGS

Kiriakos SIDERAKIS

Department of Electrical Engineering, Technological Educational Institute (T.E.I.) of Crete
710 04, Iraklion Crete, Greece
Email: k.siderakis@gmail.com

Dionisios PYLARINOS

Department of Electrical and Computer Engineering, University Of Patras
University Campus, 26500, Rio, Patras, Greece
Email: dpylarinos@yahoo.com

Emmanuel THALASSINAKIS

Islands Network Operations Department, Public Power Corporation (PPC),
Terma Kastorias Str, Katsambas, Iraklion Crete
Email: e.thalassinakis@dei.com.gr

Isidoros VITELLAS

Islands Network Operations Department, Public Power Corporation (PPC),
30 Halkokondili Str. 10432, Athens, Greece
Email: i.vitellas@dei.com.gr

Abstract: *Pollution of high voltage insulators is a problem for outdoor substation installations as in the case of transmission lines. Composite materials can provide a solution in this case also. However there are limitations especially for the already installed equipment, where the use of composite housings is not technically or financially in profit for the electrical utility. RTV SIR coatings are an efficient alternative in this case, since they can demonstrate a behavior similar to a composite insulator and in the same time can be applied on the already installed equipment. In this paper the performance of coatings installed in a coastal high voltage substation is investigated by measurements of leakage current. The measurements indicated the improvement achieved by the use of coatings and further reveal the importance of the wetting mechanism, for these specific environmental conditions.*

Key words: *Pollution, substations, RTV SIR Coatings, leakage current, wetting mechanism.*

1. Introduction

In a high voltage transmission system, measurements, control, switching and protection schemes are all included in a substation facility, providing the required capabilities for establishing a safe and reliable energy transmission. Therefore, maintaining a substation in service is an issue that rises for every utility, considering the possible impact of a power outage that may take place within such an installation.

Most of the high voltage substations, over 66kV, are

outdoor installations, mainly due to financial reasons. Therefore, one of the problems due to appear, is pollution of high voltage insulators. Pollution is a problem experienced by many utilities worldwide. It is the result of the environmental influence and is capable of degrading the substation insulation in such degree, that a flashover may occur under the nominal voltage.

In order to prevent pollution flashovers much effort has been spent and many methods have been developed [1]. Many of them concern the design stage, such as the selection of the appropriate insulator geometry and creepage distance, the selection of the appropriate insulator material (porcelain, glass, semiconducting glaze and polymeric) and especially in the case of substations, the construction of enclosed installations, using air insulation or SF6. Also for the already installed equipment, pressurized water washing, silicone grease, RTV SIR Coatings and the use of extenders are the methods usually employed [1, 2].

Among them, the use of composite polymeric insulating materials, is probably the most effective and reliable method [3, 4]. Composite materials are used as housings, providing a hydrophobic surface behavior, which suspends the development of the surface conductive layer and therefore suppresses the phenomenon development. There are numerous applications today, reporting the improvement achieved with the replacement of the traditional ceramic insulators by the corresponding composite.

Nevertheless, in the case of substations, such applications are rather limited, mainly because of two reasons. Firstly, the availability of composite hollow core insulators was rather limited until 2004. Therefore even for new installations, the use of ceramic housings was the only choice. Secondly, in the case of an already installed substation, the possibility of replacing the installed equipment is also limited, due to the considerable cost of the installed equipment. Therefore, pollution maintenance methods, which can be applied on the already installed ceramic equipment, are required.

2. Application of RTV SIR Coatings

A. Applied maintenance methods

The maintenance methods usually employed in the case of the already installed substation equipment are, high pressure water washing, the installation of extenders, the use of silicone grease and Room Temperature Vulcanized Silicone Rubber Coatings.

High pressure water washing is a method widely applied, both in substations and transmission lines [3, 5, 6]. There are many issues that rise in this case, however the most important is the selection of the appropriate washing time. There is a considerable application cost, which further rises if live washing is not possible and the possibility of a flashover is increased, since a wrong time estimation may expose the insulators in intense surface activity.

Extenders are employed in order to modify the insulator design and achieve a creepage distance increment, which further corresponds to an improvement of the insulator performance [3, 5]. They are made of a composite material, usually silicone rubber and are designed especially for each insulator type (geometry). The later corresponds to an increased design and installation cost, which limits the applicability of the method. Further, being constructed by a composite material, the use of extenders on a ceramic insulator presupposes the application of an RTV SIR Coating. Otherwise these extenders will demonstrate a different performance in comparison to the rest of the leakage distance and further perform as permanent dry bands.

Silicone grease coating compounds have been used as protective coatings on ceramic insulators for more than 30 years [3]. They are composed by silicone oil and various fillers and can maintain a constant viscosity for a range of temperatures from -50 C to 200 C, thus they are capable of operating in any climate, even on hot insulators. The performance improvement achieved, occurs due to a water repellent surface and the encapsulation capability that they provide. As a result a clean surface is always demonstrated, as long as the grease coating is not saturated [3, 6].

Unfortunately, in heavily contaminated areas, a possible saturation may appear in a time period of less

than six months, which corresponds to a considerable frequent need of removal and reapplication. This is the major drawback in this case, which also limits the application scale, since the more insulators are coated the more man hours are required. In addition, there are also limitations, such as the decreased arc resistance, the effect of the water erosion and the possible loss of the surface water repellency.

Room temperature (RTV) silicone rubber coatings are available in a liquid state and after being applied on the insulator surface, they form a solid, rubber like coat [7, 8]. The performance improvement achieved, occurs due to the hydrophobic surface behavior resists the development of leakage current and dry band arcing, even in the presence of contaminants [7-16]. In this case, no encapsulation feature is present and a performance similar to a SIR composite insulator is demonstrated. The expected application lifetime can exceed a period of ten years, depending on the experienced conditions.

Consequently the use of room temperature vulcanized, appears to be in advantage, when compared to the other three. An RTV SIR Coating is always in service (washing time), can be widely applied and can provide a satisfactory lifetime.

Considering the above, Public Power Corporation (PPC), started a large scale application of RTV SIR Coatings in 66kV and 150kV high voltage substations, in areas with intense pollution problems. This application started in 1998 and today a considerably large amount of coatings is in service, some for more than ten years. In this paper the performance of a number of substation insulators, in comparison to their uncoated counterparts is presented, in relation to the experienced environmental conditions. The comparison is possible by the use of leakage current measurements, which are continuously performed, for the corresponding time period.

B. Application site

Crete is the biggest island in the Aegean Sea, Greece. Due to its coastal development the majority of the 150kV installations are located in a proximity to the sea coast. As a result intense pollution problems have been experienced, usually resulting to long duration power outages. In order to suppress the influence of pollution, high pressure water washing has been employed as the primary maintenance method, achieving after years of experience a remarkable decrease of the pollution related flashovers.

However for substations an improved maintenance method was required. The financial cost for washing is considerable, not only due to the man hours spent, but also considering that in the case of substations, live washing is not permitted in Greece by law and therefore power interruptions were necessary. The problem is even more intense in the case of step up substations, where the maintenance procedures usually

require some of the steam power generators to be stopped.

The use of RTV SIR Coatings was employed as an alternative method. As already has been mentioned, they are applied on the already installed ceramic insulation, at a user selected time, thus can be combined with other maintenance procedures. In addition as long as the materials are effective no other maintenance is required.

The first large application took place in 1998, in one of the two 150kV step up substations in Crete. Linoperamata substation, located in a distance of less than 500m from the sea coast, is exposed to the action of the sea. As a result intense pollution problems had been observed, although the creepage distance of the insulators used had been appropriately selected according to IEC815.

In a three years period the total number of 2700 ceramic insulators had been covered, employing a total material amount of 4100kg, provided by three manufactures. It must be mentioned that since the application no other maintenance method has been employed up to today

3. Leakage current monitoring & setup

Material monitoring was considered necessary in order to evaluate the application performance and the degree of incorporation to these specific environmental conditions. For the appropriate monitoring method, the following requirements were set. At first the monitored insulators are part of the substation and therefore off line (out of voltage) measurements have limited application. Secondly the insulators are exposed to the field conditions, thus continuous monitoring is necessary in order to evaluate their performance. Thirdly comparative measurements must be provided, not only in respect of the ceramic insulators but also between the coated insulators. Finally the measurements must be performed in the conditions of a high voltage substation. Among the methods usually employed [17], leakage current monitoring was selected a probably the most suitable in this case, fulfilling the above requirements [18-21]. Further a number of nine 150kV post insulators were selected to be monitored.

Leakage current is distributed on the surface of the insulator. In order to be measured, a collection ring was appropriately installed at the bottom side of each insulator and then the measured current was driven through a Hall current sensor, which demonstrates remarkably low input impedance, a bandwidth, starting from DC up to 20kHz and also a galvanic isolation of the electronic measuring system from the high voltage side.

The acquired from the sensor data are then transmitted to a central data acquisition system, which

is capable of monitoring nine current channels. Sampling is performed continuously and simultaneously for all insulators, at a rate of 2kHz for each and a resolution of 12bit. Then due to the amount of the measured data (continuous monitoring), further processing is performed and values such as min/max current, average etc over user defined intervals are stored.

Finally, the system is capable of providing synchronized measurements of leakage current, a three phase voltage system through voltage transformers and meteorological data i.e. temperature, relative humidity, precipitation and wind. The measurements setup is illustrated in figure 1. Also figure 2 is a picture of collection ring installed at the bottom of an insulator.

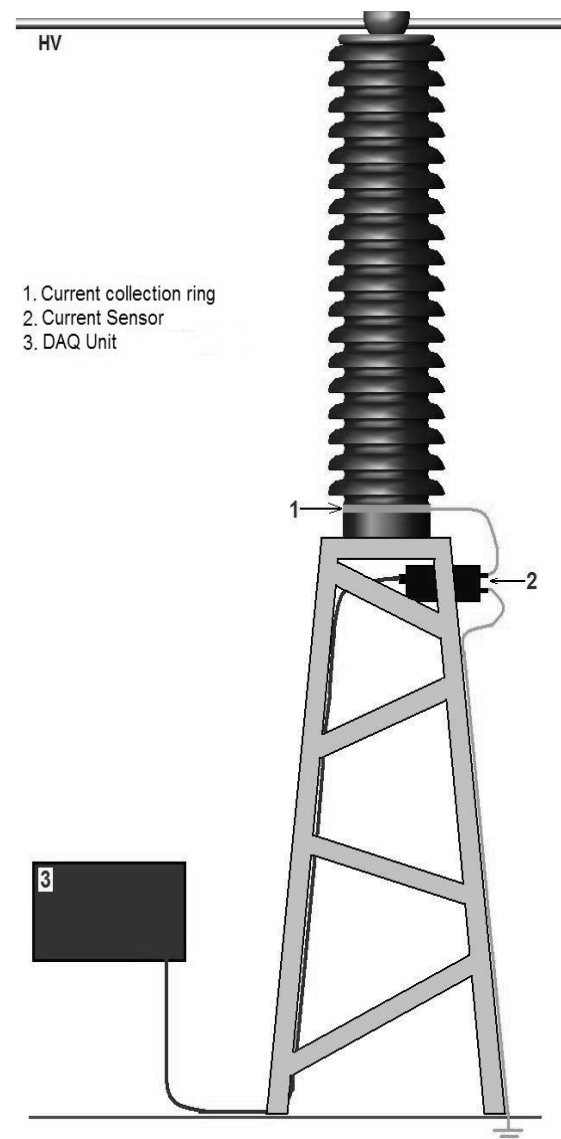

Fig.1. A schematic diagram of the data acquisition system employed for the material monitoring

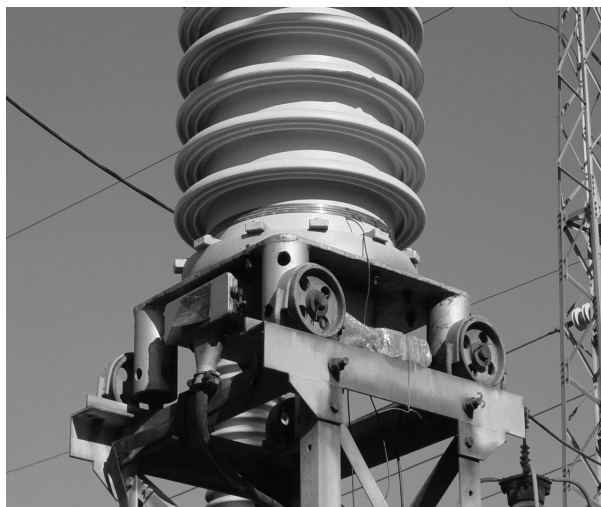

Fig.2. Installation of the current collection copper ring at the bottom of a 150kV voltage transformer

4. Investigation of leakage current measurements

The performance of porcelain insulators is considered as a reference for the RTV SIR Coatings evaluation. Therefore two out of a group of nine simultaneously monitored insulators, were not coated but instead the regular washing maintenance was employed. For these two the monthly distribution of the accumulated charge, given as the average value in the nine years monitoring period, is illustrated in figure 3.

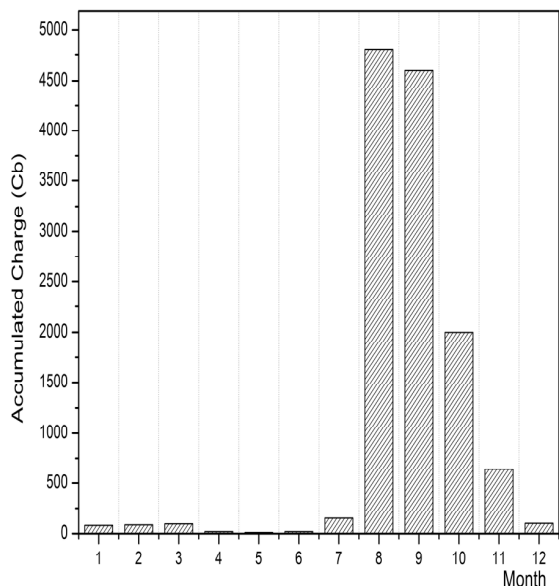

Fig.3. Monthly distribution of the accumulated charge, given as the average value in the nine years monitoring period, for the porcelain non coated insulators

The measurements indicate that the problem is

confined in a three months period, starting from August until October, while during the rest of the year the activity intensity is remarkably lower. The measurements of leakage current come in agreement with the observed surface activity and the power outages reported were the majority of the observed pollution related outages; have been recorded during the above mentioned period.

In figure 4 the monthly distribution of the accumulated charge, given as the average value for the porcelain insulators (figure 3) and the maximum value for the coated insulators, in the seven years monitoring period, is illustrated. The improvement achieved by the application of the coatings is evident from the values presented especially during the period of intense activity. However it can be seen that the surface activity on the surface of the RTV SIR coatings becomes comparable to the activity observed on the surface of uncoated insulators, in the period from December to April and especially in March.

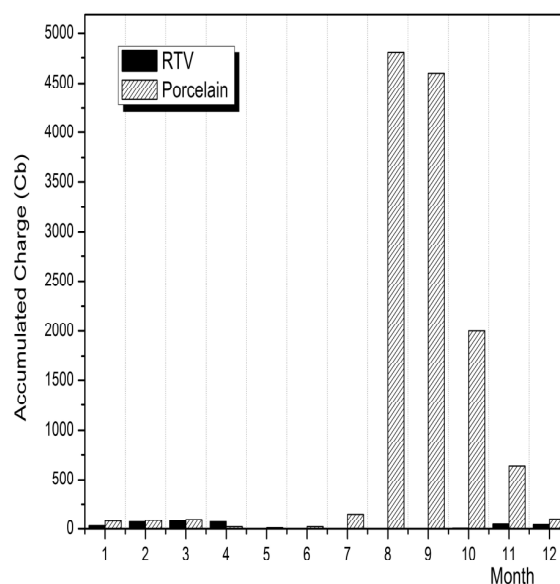

Fig.4. Monthly distribution of the accumulated charge, given as the maximum value in the nine years monitoring period, for the RTV SIR coated porcelain coated insulators.

The application of the RTV SIR Coatings can be considered as a remarkable performance improvement. Since the application, no other maintenance method has been employed and still the observed surface activity is remarkably suppressed in the case of the RTV SIR Coated insulators. However the leakage current measurements indicate that for the coated insulators there is a period of activity that needs further investigation. As it has already been mentioned,

although the remarkable difference during the summer period, from December to March, the same levels of activity have been observed both on the coated and non coated insulators. This suggests the presence of a surface mechanism, which is capable of supporting the development of surface activity on both surfaces coated and not.

Considering that the operational conditions (electrical) have not changed, the considered mechanism is probably occurring within the influence of the environment. As shown in figure 5 similar levels of wind activity are observed during both the considered periods. Thus the same amount of contamination is probably deposited on the insulator surface.

However wetting is different, as illustrated in figure 6. During August and September, when the surface activity is intense for the ceramic insulation, the observed precipitation is remarkably low and in the same time, an increased probability for RH to exceed 75%, has been recorded. Considering the phase transition of Sodium chloride particles [22], exceeding the threshold of 75% corresponds to the initiation of a condensation mechanism on the insulation surface. On the other hand at the end of the winter, both increased RH values and precipitation are observed. Therefore precipitation is probably the additional mechanism.

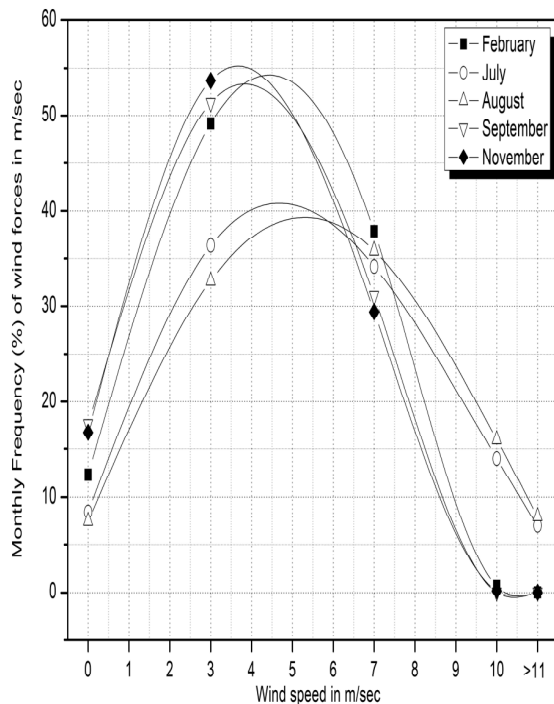

Fig.5. Monthly frequency distribution of wind forces for five typical months, including the period from July to September, during the nine years monitoring period.

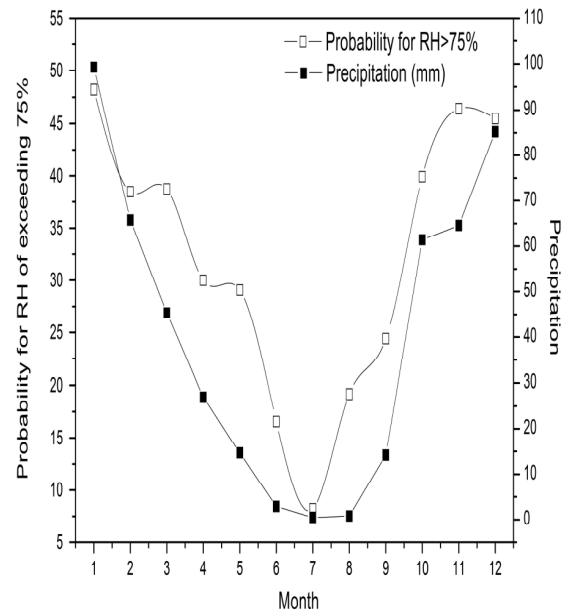

Fig.6. Average precipitation and probability for relative humidity to exceed 75% per month (data available after a 20 years monitoring period).

5. Conclusions

Substation maintenance is an issue for every utility worldwide. In the case of pollution, RTV SIR coatings can be used in order to improve the performance of ceramic insulators. In this case, after a nine years service period, such an improvement has been achieved, as it has been verified by continuous leakage current measurements. The measurements also revealed the importance of the wetting mechanism present in each application. Condensation wetting appears to have limited effect on the performance of the coated insulators. On the other hand light rain can supply larger amounts of water which can support the formation of conductive areas, where a loss of hydrophobicity has taken. As a result the surface activity observed in the case of light rain is in comparable levels as in non coated insulators.

In conclusion the coatings performance after nine years of service can be considered successful for the specific conditions. However the need for further investigation of the possible material aging is an issue that rises considering the performance in the case of light rain.

References

1. Gorur, R.S.: Accomplishments and future challenges for outdoor insulating systems under contaminated

- conditions*, International Symposium on High Voltage Engineering, India 2001
2. Gorur, R.S., Cherney, E.A, Burnham., J.T.: Outdoor Insulators, R.S.Gorur Inc, Phoenix, Arizona, USA
 3. Hackam, R.: Outdoor Composite Insulators, IEEE Transactions on DEIS, Vol 6, No 5, October 1999
 4. Gubanski, S.M.: Modern Outdoor Insulation - Concerns and challenges. Electrical Insulation Magazine, 2005. 21(6): p. 5-110p
 5. Looms J.S.T.: Insulators for high voltage, IEE Power Engineering Series 7.
 6. CIGRE WG 33-04, TF 01: A Review of current knowledge: Polluted Insulators, Cigre Publications, 1998
 7. IEEE Std 1523 – 2002: IEEE Guide for the application, maintenance and evaluation of RTV SIR Coatings for outdoor ceramic insulators, IEEE Outdoor Service Environment Committee, 2002
 8. Cherney, E.A., Gorur, R.S.: RTV SIR Coatings for Outdoor Insulators, IEEE Transactions on DEIS, Vol 6, No 5, October 1999
 9. Cherney, E.A.: RTV Silicone – A high tech solution for a dirty insulator problem, IEEE Electrical insulation Magazine, Vol. 11, No. 6, November/December 1995
 10. Hall, J., Orbeck, T.: RTV protecting coating for porcelain insulators, IEEE PES 1982 Summer Meeting, July 18 – 23 , 1982
 11. Carberry, R.E., Shneider, H.M.: Evaluation of RTV Coating for station insulators subjected to coastal contamination, IEEE Transactions on Power Delivery, Vol. 4, No. 1, January 1989
 12. IEEE DEIS Outdoor Service environment committee S-32-3: Protective coatings for improving contamination performance of outdoor high voltage ceramic insulators, IEEE Transactions on Power Delivery, Vol. 10, No. 2, April 1995
 13. Hoch, D.A., Reynders, J.P., Macey, R.E.: A silicone based hydrophobic coating for high voltage insulators, In Proceedings of the 3rd AFRICON Conference, 1992
 14. Kim, J., Chaudhury, M.K., Owen, M.J.: Hydrophobicity loss and recovery of Silicone HV Insulation, IEEE Transactions on Dielectrics and Electrical Insulation, Volume: 6, Issue: 5, October 1999, pp. 695 – 702.
 15. Hillborg, H., Gedde, U.W.: Hydrophobicity Changes in Silicone Rubbers, IEEE Transactions on Dielectrics and Electrical Insulation, Volume: 6, Issue: 5, October 1999, pp. 603 – 717.
 16. Kim, S.H., Cherney, E.A., Hackam, R.: Hydrophobic behavior of insulators coated with RTV Silicone Rubber, IEEE Transactions on Dielectrics and Electrical Insulation, Volume: 27, Issue: 3, June 1992, pp. 610 – 622.
 17. CIGRE WG 33-04: The measurement of site pollution severity and its application to insulator dimensioning for a.c. systems, Electra No.64 pp. 101-116
 18. Sorqvist T.: Polymeric Outdoor Insulators, A Long-term Study, PhD, Technical report No. 313, Chalmers University of Technology, Goteborg, SWEDEN 1997
 19. Vosloo W.L., Holtzhausen J.P., Roediger A.H.A.: Leakage current performance of naturally aged non ceramic insulators under a severe marine environment, In Proceedings of the Afficon Conference, South Africa 1996
 20. Munteanu R.: Use of Leakage Current Monitoring System for maintenance of insulators on a HV Network, In Proceedings of the 3rd World Conf. on Insulators, Arresters and Bushings, Malaga, Spain, 2003
 21. M.A.R.M. Fernando, S.M. Gubanski: Leakage Current Patterns on non Ceramic Insulators and Materials, IEEE Transactions on DEIS, Vol 6, No 5, October 1999
 22. Houghton, D.D.: Handbook of applied meteorology, New York, Wiley, 1985, ISBN : 0471084042 : 61.95